

BUCKET SELECTION GUIDE

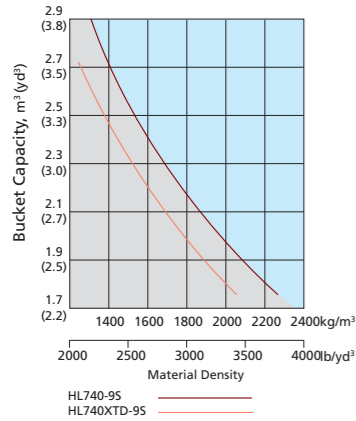

SUPPLEMENTAL SPECIFICATIONS

Description	Change in operating weight kg(lb)	Change in static tipping load-straight kg(lb)	Change in static tipping load-40° turn kg(lb)
17.5-25 12PR L2	-308 (-679)	-220 (-480)	-190 (-420)
17.5-25 12PR L3	-248 (-547)	-170 (-375)	-150 (-330)
20.5-25 16PR L2	-64 (-141)	-45 (-100)	-40 (-90)
17.5 R25 XHA*	-160 (-353)	-110 (-240)	-100 (-220)
20.5 R25 XHA*	+507 (+1,118)	+360 (+790)	+310 (+680)

STANDARD EQUIPMENT

<p>Electrical system Alternator, 70A Alarms, audible and visual - air filter clogging - transmission error - alternator voltage - brake oil pressure - engine oil pressure - parking brake - fuel level - hydraulic oil temperature - coolant temperature - service brake oil pressure Alarm, back-up Batteries, 820 CCA, 12V, (2) Gauges - engine coolant temperature - fuel level - hydraulic oil temperature - speedometer - transmission oil temperature - voltmeter Horn, electric Indicator lights - clutch cut-off - high beam - turn signal LCD Display - clock and fault code - operating hour counter - engine rpm</p>	<p>- transmission gear range indicator - job time and distance - temperature(coolant, hydraulic oil, T/M oil) Lighting system - LED dome lights - 2 stop and tail lights - 4 turn signals - brake lights(counterweight) - 2 head lights on front tower - 2 working lights on front roof - 2 working lights on rear roof Switches - work load - clutch cut-off - hazard - Ignition key, start/stop switch - main light(illumination and head light) - parking - rear wiper & washer - work light - battery mater switch - pilot cut-off Starter, electric Starting and charging system (24-volt) Cab Cab (sound suppressed and</p>	<p>pressurized) with : - cigar lighter & ashtray - coat hook Automatic climate control - air conditioner & heater - defroster - intermittent wiper and washer, front and rear - personal storage space: holder, can and cup - Rear view mirrors (1 inside) - Rear view mirrors (2 outside) - 2" retractable seat belt & adjustable suspension seat with armrests - tilt / telescopic steering column - steering wheel with knob - roller type sunshade (front / rear window) - tinted safety glass Magazine pocket Pedals - one accelerator pedal - one brake pedal Rubber floor mat Wrist rest Radio/USB player Engine Antifreeze</p>	<p>Engine, Cummins 6BTA5.9 - low Emission Diesel, Tier-1 Engine enclosure, lockable Engine fuel priming pump Fan guard Fuel/Water separator Muffler, under hood with large exhaust stack Rain cap, engine air intake Radiator (deaeration type) Power Train Brakes : Service, enclosed wet-disc Parking brake Torque converter Transmission, computer-controlled, electronic soft shift, auto-shift and quick-shift features included Transmission oil cooler Hydraulics Boom kickout, automatic Bucket positioner, automatic Diagnostic pressure taps Hydraulic system, - 2 spool, single lever, pilot control for boom and bucket actuation Steering, load-sensing Remote cooling fan, hydraulically-driven, temperature</p>	<p>sensing type Others Articulation locking bar Coolant level sight gauge Counterweight Door and cab locks, one key Doors, service access(locking) Drawbar with pin Engine oil level dipstick gauge Ergonomically located and slip resistant, left & right - handrails - ladders - platforms - steps Fenders(front/rear) Hydraulic oil level sight gauge License plate bracket Lift and tie-down hooks Steering stops, cushioned Tires(20.5-25, 16PR,L3) Transmission oil gauge level Vandalism protection caplocks</p>
---	---	--	--	---

OPTIONAL EQUIPMENT

<p>24-volt to 12-volt DC converter Cab, ROPS(ISO3471)/FOPS(ISO3449) Climate control : - air conditioner only - heater only Beacon light, rotating Auxiliary, 2 working lights on front roof (Xenon working lights) Auxiliary, 2 working lights on rear roof 3 piece cutting edge, bolt-on type</p>	<p>Secondary steering system Fire extinguisher High lift arrangement with optional counterweight, 900 kg (1,980 lb) 3rd spool for auxiliary function Mud guard Operator suit Ride control system Heated rear view mirrors (2 outside) Seat - 2" static seat belt &</p>	<p>adjustable mechanical suspension(vinyl) - 3" static seat belt & adjustable mechanical suspension - 2" retractable seat belt & adjustable air suspension (heated) Fuel warmer Tires : - 17.5 - 25, 12PR, L2 - 17.5 - 25, 12PR, L3</p>	<p>- 20.5 - 25, 16PR, L2 - 17.5 R25 XHA - 20.5 R25 XHA Tool kit Tooth, 1 piece, bolt-on type Guards - crankcase - transmission Wheel chock HI-Mate (Remote Management System) Rear view camera</p>	<p>License plate & lamp Pre-cleaner engine air intake Limited slip differential Heavy duty rear axle Reversible cooling fan</p>
--	--	--	--	---

Standard and optional equipment may vary. Contact your Hyundai dealer for more information. The machine may vary according to International standards. All imperial measurements rounded off to the nearest pound or inch.

PLEASE CONTACT

www.hyundai-ce.com

2012. 3 Rev. 0

HYUNDAI
HEAVY INDUSTRIES CO.,LTD.
CONSTRUCTION EQUIPMENT

Head Office
1000 BANGGEOJINSUNHWAN-DORO, DONG-GU, ULSAN, 682-792, KOREA
TEL:(82)52-202-7722, 9807 FAX:(82)52-202-7720



We build a better future

HL740-9S



*Photo may include optional equipment.

HYUNDAI
HEAVY INDUSTRIES CO.,LTD.

Pride at Work

Hyundai Heavy Industries strives to build state-of-the-art earthmoving equipment to give every operator maximum performance, more precision, versatile machine preferences, and proven quality. Take pride in your work with Hyundai!

HL740-9S

Machine Walk-Around

Reliable Main Components

Engine Technology

Well proven, reliable, fuel efficient, low noise Cummins 6BTA5.9 engine.
Robust Bosch in-line mechanical fuel injection pump.
-The most durable fuel system in the most harshest working environments.

Fully Automatic Transmission

4 step(Manual / Light / Normal / Heavy) shift mode by working condition
Protective transmission at low temperature(Automatic warm-up system)
Self-diagnostic & Memory of malfunction history
Minimum travel shift shock by applying proportional controlling modulation valve / Self adjusting Clutch gap
Kick-down button

Axle

Self-adjusting & wet disc brake

Improved Durability

Long-life cooling system, designed for additional durability, resistant to thermal shock, impulse and vibration.

Enhanced Operator Comfort

Improved Visibility

Larger operator's cab for additional comfort.
Redesigned cab with rounded front glass and larger door glass for a larger field of view.

Improved Convenience

Increased cooling & heating capacity with fully automatic climate control system.
Tilting & telescopic steering column.
Adjustable wrist rest for reduced operating stress.
Multiple storage compartments.
AM/FM Radio with MP3 interface and USB input.
Improved ladder with 20 Degree incline and large, deep tread, steps for safer access and exit from the cab.

Advanced 5.7" Color Monitor

Easy-to-read new color LCD display.
Auto boom kick out and bucket positioner - viewable through the monitor, for improved work efficiency and overload prevention.
Self diagnostic & monitoring system with active display of hydraulic system, transmission and electrical component information.
Color, rear-view, back-up camera for improved safety and convenience.(Option)
RMS(Remote Management System) works through GPS/satellite technology to provide better customer service and support.(Option)

Serviceability

Reversible, (Option) swing-out, cooling fan for easy service and improved cooler maintenance.
Ground level access to critical service points, filters and sight gauges for easy maintenance.



*Photo may include optional equipment.

Operator Comfort

Operating a 9S series wheel loader is unique to every operator. Operators can fully customize their work environment and operating preferences to fit their individual needs.



*Photo may include optional equipment.



Wide and Convenient Cab

The newly designed cabin was conceived for more space, a wider field of view and operator comfort. The front glass is rounded and 17% wider than the previous 7A series. Special attention was given to a clean, open and convenient interior with plenty of visibility on the machine surroundings and the job at hand. This well balanced combination of cab ergonomics puts the operator in the perfect position to work safely and securely. The 9S series cab's fully automatic climate control system features 11 air vents and increased cooling and heating capacity for optimum temperature control. The defroster vents located on the front and rear windows and a PTC (electric pre-heater, Option) make working in cold weather more hospitable.

Operator Comfort

In the 9S series cabin you can easily adjust the steering column and wrist rest to best suit your preferred comfort level. Pilot-operated joystick controls are easy and comfortable to operate. Roller type sunshades on the front & rear window allow the operator to reduce glare and improve visibility. Heated side mirrors feature built-in hot wires for quick defrosting during cold weather conditions.

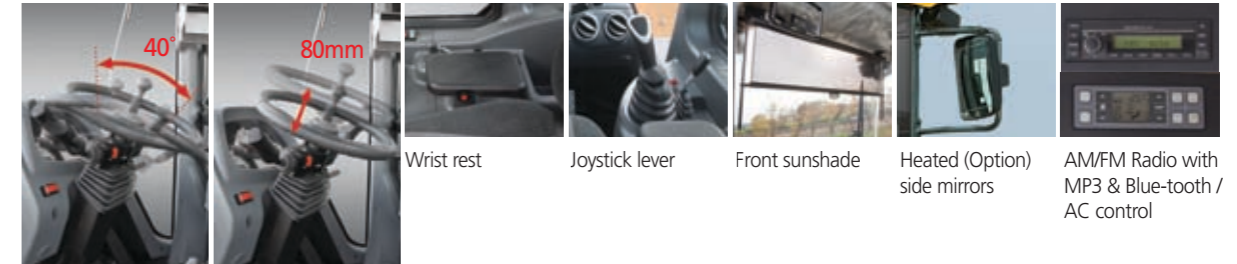

Tilting / telescopic steering column

Reduced Stress

Work is stressful enough. Your work environment should be stress free. Hyundai's 9S series cabin offers lots of amenities, additional space and a comfortable seat to minimize stress to the operator. A powerful climate control system provides the operator with optimum air temperature. An advanced audio system with AM/FM stereo with MP3 interface with Blue-tooth hands-free and USB input, plus Blue-tooth hands-free controls.

Advanced Color Monitor



The advanced new monitor with 5.7 inch wide color LCD screen allows the operator to easily and efficiently control the machine. Self diagnostics, color rear-view camera maintenance check lists and start-up machine security, were integrated into the monitor to make the machine more versatile and the operator more productive. The new monitor display unit is mounted on an adjustable swivel mount to reduce glare and position according to operator preference.

Monitor Tilt Range

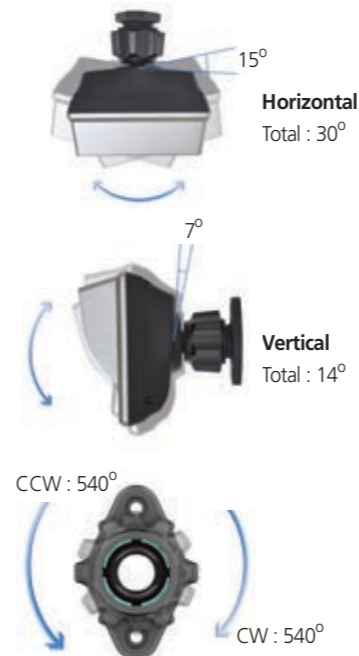

Precision & Performance

Innovative hydraulic system technologies make the 9S series wheel loader fast, smooth and easy to control. 9S series wheel loaders are designed for maximum performance to keep the operator working productively.



Improved Durability & Reliability



An enhanced axle improves driving over variable ground conditions. Self adjusting brakes that automatically regulate disc clearance, reduce service time and improve brake reliability and performance. Service and clean-out are easier on the 9S series, now equipped with a completely redesigned, parallel-mounted, cooler configuration and non louvered fins to prevent clogging. All coolers are designed with aluminum bar plate configuration and undergo strict factory tests for thermal shock, impulse and vibration to assure long term durability. Top mounted non-louvered aluminum air condenser and variable displacement A/C compressor are designed for maximum cooling capacity, energy savings and easy clean-out.

Variable Operating Modes



9S series wheel loaders are designed to allow the operator to customize automatic transmission shift timing and clutch cut-off activation based on the job condition and personal operator preference. Convenient rotary type switches allow for easy adjustment of transmission power shift mode, and clutch cut-off mode. Additionally, if equipped with the optional ride control system, the operator has the option to turn the system on or off with an overhead switch. The ride control system has a shock absorbing accumulator that cushions the boom, improves operator comfort and reduces material loss. The versatility of the 9S series operating modes contributes to improved productivity, enhanced operator comfort and reduced fuel consumption.

4 Mode Transmission Power Shift System

- M(Manual) Mode
- Auto L(Light) Mode : Light duty & long distance carry
- Auto N(Normal) Mode : General excavating & loading
- Auto H(Heavy) Mode : Heavy duty excavating & loading

3 Mode Clutch Cut-Off System

- L(Low) Mode : Short distance & faster loading
- M(Medium) Mode : General loading
- H(High) Mode : Slope ground

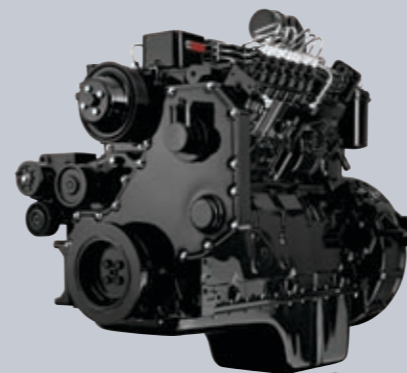

Powerful
Cummins 6BTA5.9 Engine

Cummins 6BTA5.9 engine meets Tier1 emission standard. Cummins 6BTA5.9 engines have been proven durable and reliable in some of the most remote locations and harshest working environments in the world. A robust in-line fuel pump delivers more power at high injection pressure for cleaner combustion and lower emission. Holset HX35 turbocharger optimizes response across the torque curve.



Fully Automatic
Transmission

Fully automatic transmission designed for maximum durability, Minimum power loss, improved travel speed and low noise. Improved clutch control and minimized shifting shock when traveling, contribute to a smoother ride. Error messages and transmission fault history are recorded and accessible through the monitor.

*Photo may include optional equipment.

Profitability

9S series is designed to maximize profitability through improved efficiencies, enhanced service features and longer life components.



Hi-mate [Remote Management System](Option)

Hi-mate, Hyundai's proprietary remote management system, provides operators and dealer service personnel access to vital service and diagnostic information on the machine from any computer with internet access. Users can pinpoint machine location using digital mapping and set machine work boundaries, reducing the need for multiple service calls. Hi-mate saves time and money for the owner and dealer by promoting preventative maintenance and reducing machine downtime.



Remote-mounted Cooling Fan

The remote mounted, hydraulically powered cooling fan regulates fan speed according to working temperatures for coolant, intake air, transmission oil and hydraulic oil. This new fan design contributes to reduced fuel consumption and machine noise. (Option : The fan is designed to auto reverse periodically or manually reverse to keep debris from accumulating on the coolers.)



Easy Access

The cooling fan is integrated into the rear door which swings open to over 45 degrees for easy access and regular maintenance. Conveniently located coolant and transmission oil site gauges make checking fluid levels fast and efficient. Ground-line access to fuel and oil filters grease fittings, fuses, machine computer components and wide open compartments makes service more convenient on the 9S series.



Full Fenders and Mud Guards (Option)

9S series wheel loaders can be equipped with front, rear fenders and optional mud guards to reduce material splatter to the cab and machine frame.



Hydraulic Oil
(5,000 hr)

Extended Life Components

The 9S series is designed for longer lubrication intervals and extended component life. Hydraulic oil can last up to 5,000 hours before changing. Also, a new center pivot roller bearing design, now double tapered, requires less maintenance as well. Long life and extended wear components save the operator time and money.

*Photo may include optional equipment.

Specifications & Dimensions

ENGINE

Maker/Model	Cummins 6BTA5.9
Type	Watercooled, 4-cycle, turbocharged, direct injection, mechanical controlled diesel engine
Gross power	150 HP(112 kW) / 2,200rpm
Net power	143 HP(107 kW) / 2,200rpm
Maximum torque	68 kg-m(493 lb-ft) / 1,400rpm
No. of cylinders	6

※ No derating for continuous operating required up to 2,255m (7,400ft).

Bore x Stroke	102 mm (4.02") x 120 mm (4.72")
Displacement	5.9 l (359 cu in)
Compression ratio	17.6 : 1
Air cleaner	Dry, Two stages dual elements
Alternator	24V, 90 Amp
Battery	2 x 12V, 115 Ah.
Starting motor	24V, 4.5 kW

TRANSMISSION

Torque converter type	3-elements, single-stage single-phase
Tire	20.5-25, L3

※Full automatic power shift, countershaft type with soft-shift in range and direction. Properly matched torque converter to engine and transmission for excellent working ability.

Travel speed		km/h (mph)
Forward	1st	6.9(4.3)
	2nd	12.5(7.8)
	3rd	24.1(15.0)
	4th	40.0(24.9)
Reverse	1st	7.2(4.5)
	2nd	13.2(8.2)
	3rd	25.3(15.7)

AXLES

Drive system	Four-wheel drive system
Mount	Rigid front axle and oscillating rear axle
Rear axle oscillation	±12° (total 24°)

Hub reduction	Planetary reduction at wheel end
Differential	Conventional
Reduction ratio	22.0

HYDRAULIC SYSTEM

Type	Open center system
Pump	167 liters/min (44.2 gal/min)
Control valve	2spool (Bucket, Boom) 3spool (Bucket, Boom, Aux) Pilot pressure controlled type System pressure : 210 kgf/cm ² (2986PSI)

Bucket Controls	Type	Pilot operated lift and tilt circuit, single-lever(joystick) control standard.
	Lift Circuit	The valve has four functions ; raise, hold, lower and float. Can adjust automatic kickout from horizontal to full lift.
	Tilt Circuit	The valve has three functions ; tilt back, hold and dump. Can adjust automatic bucket positioner to desired load angle.
Cylinders		Type : Double acting No. of cylinders-bore x stroke; Lift HL740-9S/740XTD-9S 2-ø120 mm x 738 mm(4.3" x 29.5") Tilt HL740-9S/740XTD-9S ø140 mm x 505 mm(4.9" x 19.9")
Cycle Time		HL740-9S / HL740XTD-9S
	Raise(with load)	5.8 sec
	Dump	1.3 sec
	Lower(empty)	3.1 sec
	Total	10.2 sec

BRAKES

Service Brakes	Hydraulically actuated, wet disc brakes actuate all 4 wheels independent axle-by-axle system Self adjusting & in board brake
Parking Brake	Spring-applied, hydraulically released brake in Front Axle
Emergency Brake	When brake oil pressure drops, indicator light alerts operator and parking brake automatically applies.

SERVICE REFILL CAPACITIES

Fuel tank	230 liters (60.8 USgal)
Cooling system	34 liters (9.0 USgal)
Crankcase	15 liters (4.0 USgal)
Transmission	25 liters (6.6 USgal)

OVERVIEW

Description	UNIT	HL740-9S	HL740XTD-9S
Operating weight	kg (lb)	11,550 (25,460)	11,850 (26,120)
Bucket capacity	Heaped	m ³ (yd ³) 2.1 (2.7)	2.1 (2.7)
	Struck	m ³ (yd ³) 1.78 (2.3)	1.78 (2.3)
Breakout force-bucket	kg (lb)	11,880 (26,190)	11,730 (25,860)
Tipping load	Straight	kg (lb) 9,120 (20,110)	8,320 (18,340)
	Full turn	kg (lb) 7,890 (17,390)	7,130 (15,720)

DIMENSIONS

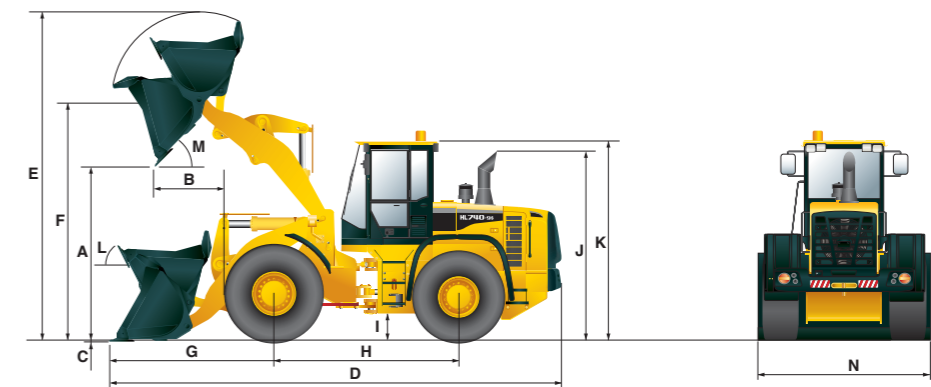

Description	UNIT	HL740-9S	HL740XTD-9S
Bucket Type	General purpose bolt-on cutting edge		
A. Dumping clearance at max. height and 45° dump angle.	mm (ft-in)	2,850 (9' 4")	3,270 (10' 9")
B. Reach	Full lift	mm (ft-in) 970 (3' 2")	965 (3' 2")
	7ft height	mm (ft-in) 1,500 (4' 11")	1,860 (6' 1")
C. Digging depth	mm (in)	93 (3.7")	130 (5.1")
D. Overall length	on ground	mm (ft-in) 7,260 (23' 10")	7,710 (25' 4")
	at carry	mm (ft-in) 7,210 (23' 8")	7,685 (25' 3")
E. Overall height (fully raised)	mm (ft-in)	5,070 (16' 8")	5,480 (18')
F. Bucket pivot max. height	mm (ft-in)	3,830 (12' 7")	4,250 (13' 11")

STEERING SYSTEM

Type	Load-sensing hydrostatic articulated steering	
Pump	Gear type, 83.5 l/min (22.1 gal/min)@governed rpm	
Relief Valve Setting	210 kg/cm ² (2,986 psi)	
Cylinder	Type	Double acting
	Bore x Stroke	65mm x 429mm(2.6" x 16.9")
Steering Angle	40°(each direction)	

Features

- Center-point frame articulation. - Tilt and telescopic steering column.

Front axle	21.8 liters (5.8 USgal)
Rear axle	21.8 liters (5.8 USgal)
Hydraulic tank	106 liters (28 USgal)
Hydraulic system (including tank)	154 liters (40.7 USgal)

TIRES

Type	Tubeless, loader design tires
Standard	20.5-25, 16 PR, L3
Options include	17.5-25, 12 PR, L3 20.5-25, 16 PR, L2 20.5 R25 XHA* 20.5-25, 16 PR, L5