

## BUCKET SELECTION GUIDE

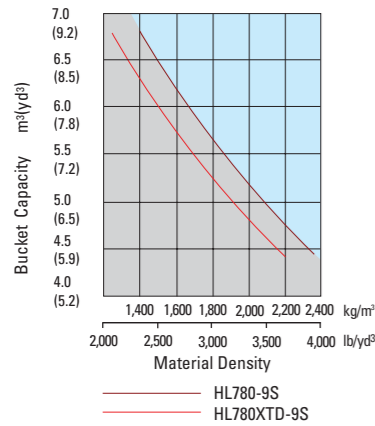

## SUPPLEMENTAL SPECIFICATIONS

Description	Change in operating weight kg(lb)	Change in static tipping load-straight kg(lb)	Change in static tipping load-40° turn kg(lb)
26.5-25 32PR L3	-112 (-247)	-90 (-200)	-80 (-175)
29.5-25 28PR L3	+352 (+776)	+270 (+595)	+240 (+530)
29.5-25 28PR L5	+1,240 (+2,734)	+960 (+2,160)	+850 (+1,870)
29.5 R25 XHA*	+500 (+1,102)	+390 (+860)	+340 (+750)

## STANDARD EQUIPMENT

<p><b>Electrical system</b> Alternator, 70A Alarms, audible and visual - air filter clogging - transmission error - alternator voltage - brake oil pressure - engine oil pressure - parking brake - fuel level - hydraulic oil temperature - coolant temperature - service brake oil pressure Alarm, back-up Batteries, 1,315 CCA, 12V, (2) Gauges - engine coolant temperature - fuel level - hydraulic oil temperature - speedometer - transmission oil temperature - voltmeter Horn, electric Indicator lights - clutch cut-off - high beam - turn signal LCD Display - clock and fault code - operating hour counter - engine rpm</p>	<p>- transmission gear range indicator - job time and distance - temperature(coolant, hydraulic oil, t/m oil) Lighting system - 1 LED dome lights - 2 stop and tail lights - 4 turn signals - brake lights(counterweight) - 2 head lights on front tower - 2 working lights on front roof - 2 working lights on grill Switches - clutch cut-off - hazard - Ignition key, start/stop switch - main light(illumination and head light) - parking - rear wiper &amp; washer - work light - battery master switch Starter, electric Starting and charging system(24-volt)  <b>Cab</b> Cab(sound suppressed and pressurized) with : - cigar lighter &amp; ashtray - coat hook</p>	<p>Automatic climate control - air conditioner &amp; heater - defroster - intermittent wiper and washer, front and rear - personal storage space: Console box Holder, can and cup Rear view mirrors (1 inside) Rear view mirrors (2 outside) 2" static seat belt &amp; mechanical suspension seat with armrests Steering column, tilt and telescopic Steering wheel with knob Roller type sunshade (front / rear window) Tinted safety glass Two door cab Magazine pocket Pedals - one accelerator pedal - one brake pedal Radio/USB player Rubber floor mat Wrist rest Roller type sunshade (rear window)  <b>Engine</b> Antifreeze Engine, Cummins QSM11</p>	<p>- Low Emission Diesel, Tier3 Engine enclosure, lockable 3 operating mode (power / standard / econo) Fan guard Fuel/water separator Fuel warmer Muffler, under hood with large exhaust stack Rain cap, engine air intake Radiator Starting aid (air intake heater)  <b>Power Train</b> Brakes : Service, enclosed wet-disc Differentials Parking brake Torque converter Transmission, computer-controlled, electronic soft shift, auto-shift and kick-shift features included Transmission oil cooler  <b>Hydraulics</b> Boom kickout, automatic Bucket positioner, automatic Diagnostic pressure taps Hydraulic oil cooler Hydraulic system, - 2 spool, single lever, pilot control for boom and bucket actuation</p>	<p>Steering, load-sensing Remote cooling fan, hydraulically-driven, temperature sensing type  <b>Others</b> Articulation locking bar Coolant level sight gauge Counterweight Door and cab locks, one key Doors, service access(locking) Drawbar with pin Engine oil level dipstick gauge Ergonomically located and slip resistant, left &amp; right - handrails - ladders - platforms - steps Fenders(front / rear) Guard, bucket cylinder rod Hydraulic oil level sight gauge Lift and tie-down hooks Loader linkage, sealed Z-Bar design Steering stops, cushioned Tires(29.5-25, 22PR,L3) Transmission oil site level Vandalism protection caplocks</p>
---	--	--	--	--

## OPTIONAL EQUIPMENT

<p>24-volt to 12-volt DC converter 3 Spool Climate control - air conditioner only - heater only Beacon light, rotating Auxiliary, 2 working lights on front roof (Xenon working lights) Auxiliary, 2 working lights on rear roof Cutting edge, bolt-on type Dual brake pedal</p>	<p>Secondary steering system Fire extinguisher High lift arrangement with additional counterweight, 552kg(1,210lb) 3rd spool for auxiliary function Operator suit Mud guard Pallet forks Heated rear view mirrors (2 outside)</p>	<p>Reversible cooling fan Ride control system Seat - 2" retractable seat belt &amp; adjustable mechanical suspension (vinyl) - 3" retractable seat belt &amp; adjustable mechanical suspension - 2" retractable seat belt &amp; adjustable air suspension (heated)</p>	<p>Cab, ROPS / FOPS Tires : - 29.5 - 25, 28PR L3 - 29.5 - 25, 28PR L5 - 26.5 - 25, 32PR L3 - 29.5 R25 XHA* Tool kit Tooth, 2 pieces, bolt-on type Wheel chock Pre-cleaner, engine air intake License plate &amp; lamp</p>	<p>Hi-Mate(Remote Management System) Rearview camera Heavy duty axle (Front, Rear) Axle cooling system Hyd, lock differential(Front) 3rd fuel prefilter</p>
--	---	--	---	---

Standard and optional equipment may vary. Contact your Hyundai dealer for more information. The machine may vary according to International standards. All imperial measurements rounded off to the nearest pound or inch.

PLEASE CONTACT

www.hyundai-ce.com

2012. 7 Rev 0

**HYUNDAI**  
HEAVY INDUSTRIES CO.,LTD.  
**CONSTRUCTION EQUIPMENT**

Head Office  
1000 BANGEOJINSUNHWAN-DORO, DONG-GU, ULSAN, 682-792, KOREA  
TEL:(82)52-202-7722, 9807 FAX:(82)52-202-7720



We build a better future

# HL780-9S

With Tier 3 Engine installed



\*Photo may include optional equipment.

**HYUNDAI**  
HEAVY INDUSTRIES CO.,LTD.

# Pride at Work

Hyundai Heavy Industries strives to build state-of-the-art earthmoving equipment to give every operator maximum performance, more precision, versatile machine preferences, and proven quality. Take pride in your work with Hyundai!



\*Photo may include optional equipment.

## HL780-9S

### Machine Walk-Around

#### Reliable Main Components

##### Engine Technology

Well Proven, reliable, fuel efficient, low noise Cummins Tier-III QSM11 engine.  
3 Engine operating mode(Power / Standard / Econo)

##### Fully Automatic Transmission

4 step(Manual / Light / Normal / Heavy) shift mode by working condition  
Protective transmission at low temperature(Automatic warm-up system)  
Self-diagnostic & Memory of malfunction history  
Minimum travel shift shock by applying proportional controlling modulation valve / Self adjusting  
Clutch gap  
Kick-down button

##### Axle

Wheel speed wet disc brake

#### Improved Durability

Long-life cooling system, designed for additional durability, resistant to thermal shock, impulse and vibration.

#### Enhanced Operator Comfort

##### Improved Visibility

Larger operator's cab for additional comfort.  
Redesigned cab with rounded front glass and larger door glass for a larger field of view.

##### Improved Convenience

Increased cooling & heating capacity with fully automatic climate control system.  
Tilting & telescopic steering column.  
Adjustable wrist rest for reduced operating stress.  
Multiple storage compartments.  
AM/FM Radio with MP3 interface and USB input.  
Improved ladder with 20 Degree incline and large, deep tread, non-slip steps for safer access and exit from the cab.

##### Advanced 5.7" Color Monitor

Easy-to-read new color LCD display.  
Self diagnostic & monitoring system with active display of hydraulic system, transmission and electrical component information.  
Color, rear-view, back-up camera for improved safety and convenience.  
RMS(Remote Management System) works through GPS/satellite technology to provide better customer service and support.

#### Serviceability

Reversible, swing-out, cooling fan for easy service and improved cooler maintenance.  
Ground level access to critical service points, filters and sight gauges for easy maintenance.

# Operator Comfort

Operating a 9S series wheel loader is unique to every operator. Operators can fully customize their work environment and operating preferences to fit their individual needs.



\*Photo may include optional equipment.



## Wide and Convenient Cab

The newly designed cabin was conceived for more space, a wider field of view and operator comfort. The front glass is rounded and 17% wider than the previous 7A series. Special attention was given to a clean, open and convenient interior with plenty of visibility on the machine surroundings and the job at hand. This well balanced combination of cab ergonomics puts the operator in the perfect position to work safely and securely. The 9S series cab's fully automatic climate control system features 11 air vents and increased cooling and heating capacity for optimum temperature control. The defroster vents located on the front and rear windows and a PTC (electric pre-heater, Option) make working in cold weather more hospitable.

## Operator Comfort

In the 9S series cabin you can easily adjust the steering column and wrist rest to best suit your preferred comfort level. Pilot-operated joystick controls are easy and comfortable to operate. Roller type sunshades on the front window allow the operator to reduce glare and improve visibility. Heated side mirrors feature built-in hot wires for quick defrosting during cold weather conditions.

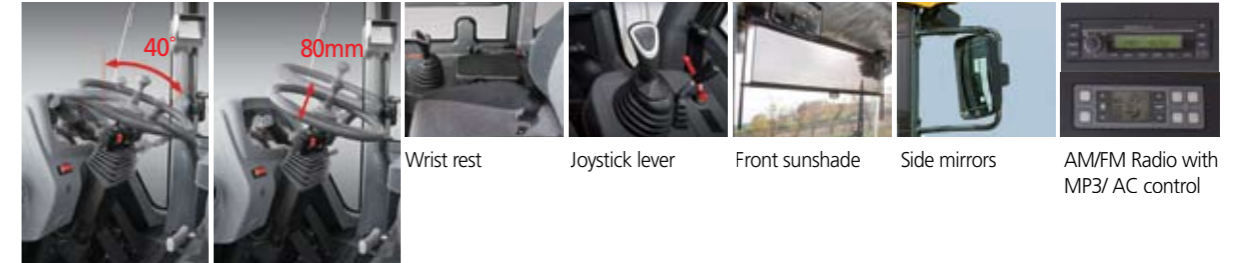

Tilting / telescopic steering column

## Reduced Stress

Work is stressful enough. Your work environment should be stress free. Hyundai's 9S series cabin offers lots of amenities, additional space and a comfortable seat to minimize stress to the operator. A powerful climate control system provides the operator with optimum air temperature. An advanced audio system with AM/FM stereo with MP3 interface and USB input, plus remotely located controls is perfect for listening to music favorites.

## Advanced Color Monitor



The advanced new monitor with 5.7 inch wide color LCD screen allows the operator to easily and efficiently control the machine. Self diagnostics, color rear-view camera maintenance check lists and start-up machine security, were integrated into the monitor to make the machine more versatile and the operator more productive. The new monitor display unit is mounted on an adjustable swivel mount to reduce glare and position according to operator preference.

## Monitor Tilt Range



# Precision & Performance

Innovative hydraulic system technologies make the 9S series wheel loader fast, smooth and easy to control. 9S series wheel loaders are designed for maximum performance to keep the operator working productively.



## Improved Durability & Reliability



An enhanced axle improves driving over variable ground conditions. Sintered brake discs reduce service time and improve brake reliability and performance. Service and clean-out are easier on the 9S series, now equipped with a completely redesigned, parallel-mounted, cooler configuration and non-louvered fins to prevent clogging. All coolers are designed with aluminum bar plate configuration and undergo strict factory tests for thermal shock, impulse and vibration to assure long term durability. Top mounted non-louvered aluminum air condenser and variable displacement A/C compressor are designed for maximum cooling capacity, energy savings and easy clean-out.

## Variable Operating Modes



9S series wheel loaders are designed to allow the operator to customize automatic transmission shift timing and clutch cut-off activation based on the job condition and personal operator preference. Convenient rotary type switches allow for easy adjustment of transmission power shift mode, and clutch cut-off mode. Additionally, if equipped with the optional ride control system, the operator has the option to turn the system on or off with an overhead switch. The ride control system has a shock absorbing accumulator that cushions the boom, improves operator comfort and reduces material loss. The versatility of the 9S series operating modes contributes to improved productivity, enhanced operator comfort and reduced fuel consumption.



**3 Mode Engine Power Selection**  
 P(Power) Mode : Heavy duty work  
 S(Standard) Mode : General work  
 E(Economy) Mode : Light duty work

**4 Mode Transmission Power Shift System**

M(Manual) Mode  
 Auto L(Light) Mode : Light duty & long distance carry  
 Auto N(Normal) Mode : General excavating & loading  
 Auto H(Heavy) Mode : Heavy duty excavating & loading

**ICCO(Intelligent Clutch Cut-off) System**

Improved productivity(more power available for hyd.system) and smooth control of machine speed.



Eco-friendly  
Cummins QSM11 Engine

The CUMMINS QSM11 electronic control engine combines full-authority electronic controls with the reliable performance. The combination of improved airflow and evenly dispersed fuel results in increased power, improved transient response and reduced fuel consumption. And the QSM11 uses advanced electronic controls to meet the emission standards. (EPA Tier-3, EU Stagell-A)



Fully Automatic  
Transmission

Fully automatic transmission designed for maximum durability, Minimum power loss, improved travel speed and low noise. Improved clutch control and minimized shifting shock when traveling, contribute to a smoother ride. Error messages and transmission fault history are recorded and accessible through the monitor.

\*Photo may include optional equipment.

# Profitability

9S series is designed to maximize profitability through improved efficiencies, enhanced service features and longer life components.



\*Photo may include optional equipment.



## Hi-mate (Remote Management System)

Hi-mate, Hyundai's proprietary remote management system, provides operators and dealer service personnel access to vital service and diagnostic information on the machine from any computer with internet access. Users can pinpoint machine location using digital mapping and set machine work boundaries, reducing the need for multiple service calls. Hi-mate saves time and money for the owner and dealer by promoting preventative maintenance and reducing machine downtime.



## Remote-mounted Cooling Fan

The remote mounted, hydraulically powered cooling fan regulates fan speed according to working temperatures for coolant, intake air, transmission oil and hydraulic oil. This new fan design contributes to reduced fuel consumption and machine noise. (Option: The fan is designed to auto reverse periodically or manually reverse to keep debris from accumulating on the coolers)



## Swing Out Cooling Fan

The engine fan is integrated into the rear door which swings open to over 45 degrees for easy access and regular maintenance.



## Wide Open Access

Conveniently located coolant and transmission oil site gauges make checking fluid levels fast and efficient. Ground-line access to fuel and oil filters grease fittings, fuses, machine computer components and wide open compartments makes service more convenient on the 9S series.



Hydraulic Oil  
(5,000 hr)

## Extended Life Components

The 9S series is designed for longer lubrication intervals and extended component life. Hydraulic oil can last up to 5,000 hours before changing. Also, a new center pivot roller bearing design, now double tapered, requires less maintenance as well. Long life and extended wear components save the operator time and money.

# Specifications & Dimensions

## ENGINE

<b>Maker/Model</b>	CUMMINS QSM11
<b>Type</b>	Watercooled, 4-cycle, turbocharged, charge aircooled direct injection, electronic controlled diesel engine
<b>Gross power</b>	348HP(260 kW) / 2,000rpm
<b>Net power</b>	331HP(247 kW) / 2,000rpm
<b>Maximum torque</b>	171kg.m(1,235 lb.ft) / 1,400rpm
<b>No. of cylinders</b>	6

※No derating for continuous operating required up to 3,048m (10,000ft). This engine meets the EPA(Tier III) / EU(Stage III-A) Emission regulation.

<b>Bore x Stroke</b>	125 mm (4.9") x 147 mm (5.8")
<b>Displacement</b>	10.8 l (660 cu in)
<b>Compression ratio</b>	16.3 : 1
<b>Air cleaner</b>	Dry, Two stages dual elements
<b>Alternator</b>	24V, 70 Amp
<b>Battery</b>	2 x 12V, 220 Ah.
<b>Starting motor</b>	24V, 7.5 kW

## TRANSMISSION

<b>Torque converter type</b>	3-elements, single-stage Double-phase
<b>Tire</b>	29.5-25, L3

※Full automatic power shift, countershaft type with soft-shift in range and direction. Properly matched torque converter to engine and transmission for excellent working ability

<b>Travel speed</b>		<b>km/h (mph)</b>
<b>Forward</b>	1st	6.1(3.8)
	2nd	11.5(7.1)
	3rd	18.0(11.2)
	4th	36.5(22.7)
<b>Reverse</b>	1st	6.1(3.8)
	2nd	11.5(7.1)
	3rd	25.0(15.5)

## AXLES

<b>Drive system</b>	Four-wheel drive system
<b>Mount</b>	Rigid front axle and oscillating rear axle
<b>Rear axle oscillation</b>	±13° (total 26°)

<b>Hub reduction</b>	Planetary reduction at wheel end
<b>Differential</b>	Conventional
<b>Reduction ratio</b>	27.0

## HYDRAULIC SYSTEM

<b>Type</b>	Open centered tandem circuit system
<b>Pump</b>	Vane 471 rpm 124.4 gpm
<b>Control valve</b>	2 Spool (Bucket, Boom) 3 Spool (Bucket, Boom, Aux) Pilot pressure controlled type
<b>System pressure</b>	210 kgf/cm <sup>2</sup> (2,990 psi)

<b>Bucket Controls</b>	<b>Type</b>	Pilot operated lift and tilt circuit, single-lever(joystick) control standard.
	<b>Lift Circuit</b>	The valve has four functions ; raise, hold, lower and float. Can adjust automatic kickout from horizontal to full lift.
	<b>Tilt Circuit</b>	The valve has three functions ; tilt back, hold and dump. Can adjust automatic bucket positioner to desired load angle.
<b>Cylinder</b>	<b>Type</b> : Double acting Lift, bore x stroke 2-200 mm(7.0") x 863 mm(34.0") Tilt, bore x stroke HL780-9S HL780XTD-9S 2-160 mm(5.5") x 580 mm(22.6") 2-160 mm(5.5") x 570 mm(25.4")	
<b>Cycle Time</b>	Raise : 6.7 sec (with load) Dump : 1.4 sec Lower : 3.0 sec (empty) Total : 11.1 sec	

## BRAKES

<b>Service Brakes</b>	Hydraulically actuated, wet disc brakes actuate all 4 wheels independent axle-by-axle system. Wheel speed brake.
<b>Parking Brake</b>	Spring-applied, hydraulically released disc brake on transmission output
<b>Emergency Brake</b>	When brake oil pressure drops, indicator light alerts operator and parking brake automatically applies.

## STEERING SYSTEM

<b>Type</b>	Full hydraulic power steering	
<b>Pump</b>	Vane, 264 liters/min (69.7 gal/min)	
<b>Relief Valve Setting</b>	210 kg/cm <sup>2</sup> (2,990 psi)	
<b>Cylinder</b>	Type Bore x Stroke	Double acting 110mm(4.1") x 480mm(18.9")
<b>Steering Angle</b>	40°(each direction)	

Features  
- Center-point frame articulation.  
- Load-sensing, flow amplified system.  
- Tilt and telescopic steering column.

## SERVICE REFILL CAPACITIES

<b>Fuel tank</b>	450 liters (118.8 USgal)
<b>Cooling system</b>	65 liters (17.2 USgal)
<b>Crankcase</b>	38 liters (10.0 USgal)
<b>Transmission</b>	43 liters (11.4 USgal)

<b>Front axle</b>	58 liters (15.3 USgal)
<b>Rear axle</b>	58 liters (15.3 USgal)
<b>Hydraulic tank</b>	234 liters (62 USgal)
<b>Hydraulic system (including tank)</b>	344 liters (90.8 USgal)

## OVERVIEW

Description	UNIT	HL780-9S	HL780XTD-9S
Operating weight	kg (lb)	29,500 (65,040)	30,200 (66,580)
Bucket capacity	Heaped	m <sup>3</sup> (yd <sup>3</sup> ) 5.1 (6.7)	5.1 (6.7)
	Struck	m <sup>3</sup> (yd <sup>3</sup> ) 4.3 (5.6)	4.3 (5.6)
Breakout force-bucket	kg (lb)	24,820 (54,720)	23,880 (52,650)
Tipping load	Straight	kg (lb) 23,940 (52,780)	21,660 (47,750)
	Full turn	kg (lb) 20,770 (45,790)	18,660 (41,140)

## TIRES

<b>Type</b>	Tubeless, loader design tires
<b>Standard</b>	29.5-25, 22 PR, L3
<b>Options include</b>	26.5-25, 32 PR, L3 29.5-25, 28 PR, L3 29.5-25, 28 PR, L5 29.5 R25 XHA*

## DIMENSIONS

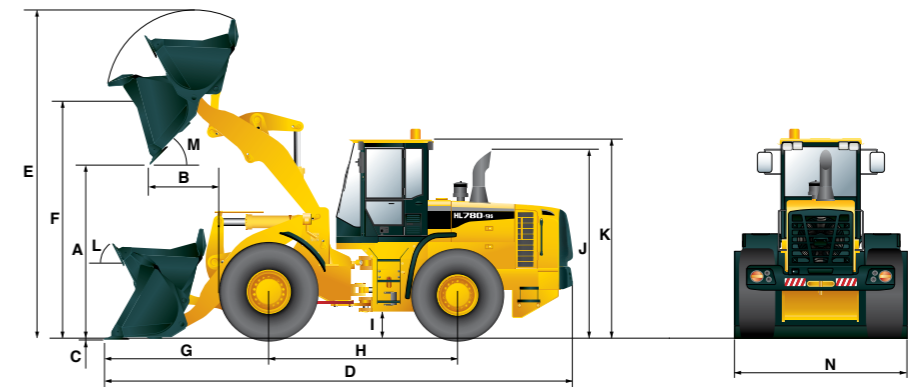

Description	UNIT	HL780-9S	HL780XTD-9S
Bucket Type	General purpose bolt-on cutting edge		
A. Dumping clearance at max. height and 45° dump angle.	mm (ft-in)	3,300 (10' 10")	3,720 (12' 2")
B. Reach	Full lift	mm (ft-in) 1,365 (4' 6")	1,430 (4' 8")
	7ft height	mm (ft-in) 2,070 (6' 9")	2,440 (8')
C. Digging depth	mm (in)	95 (3.7")	110 (4.3")
D. Overall length	on ground	mm (ft-in) 9,475 (31' 1")	9,970 (32' 9")
	at carry	mm (ft-in) 9,400 (30' 10")	9,920 (32' 7")
E. Overall height (fully raised)	mm (ft-in)	6,160 (20' 3")	6,590 (21' 7")
F. Bucket pivot max. height	mm (ft-in)	4,510 (14' 10")	4,930 (16' 2")

Description	UNIT	HL780-9S	HL780XTD-9S
G. Front overhang	mm (ft-in)	3,080 (10' 1")	3,510 (11' 6")
H. Wheelbase	mm (ft-in)	3,700 (12' 2")	3,700 (12' 2")
I. Ground clearance	mm (ft-in)	495 (1' 7")	495 (1' 7")
J. Height over exhaust	mm (ft-in)	3,720 (12' 2")	3,720 (12' 2")
K. Height over cab	mm (ft-in)	3,880 (12' 9")	3,880 (12' 9")
L. Roll-back angle (on ground/at carry)	deg	42 / 48	42 / 49
M. Dump angle	deg	47	47
Clearance circle	mm (ft-in)	15,170 (49' 9")	15,580 (51' 1")
N. Overall width	with bucket	mm (ft-in) 3,450 (11' 4")	3,450 (11' 4")
	without bucket	mm (ft-in) 3,220 (10' 7")	3,220 (10' 7")